

Claudia Lupp · Robert E. W. Hancock · Edward G. Ruby

The *Vibrio fischeri* *sapABCDF* locus is required for normal growth, both in culture and in symbiosis

Received: 22 July 2002 / Revised: 2 October 2002 / Accepted: 14 October 2002 / Published online: 9 November 2002
© Springer-Verlag 2002

Abstract Inactivation of the *sapABCDF* genes results in a loss of virulence in several bacterial pathogens of animals and plants. The role of this locus in the growth physiology of *Vibrio fischeri*, and in the symbiotic colonization of the squid *Euprymna scolopes* was investigated. In rich medium, a *V. fischeri sapA* insertion mutant grew at only 85% the rate of its wild-type parent. While a similar effect has been attributed to a potassium-transport defect in *sap* mutants of enteric bacteria, the *V. fischeri* mutant grew more slowly regardless of the potassium concentration of the medium. Similarly, the growth-rate defect was independent of the source of either carbon, nitrogen, or phosphorous, indicating that the *V. fischeri sap* genes do not encode functions required for the transport of a specific form of any of these nutrients. Finally, while a delay in colonizing the nascent light organ of the squid could be accounted for by the lower growth rate of the mutant, a small but statistically significant reduction in its final population size in the host, but not in medium, suggests that the *sap* genes play another role in the symbiosis. All of these phenotypic defects could be genetically complemented *in trans* by the *sapABCDF* genes, but not by the *sapA* gene alone, indicating that the insertion in *sapA* is polar to the four downstream genes in the locus. Thus, while the *sap* locus is important to the normal growth of *V. fischeri*, it plays different physiological roles in growth and tissue colonization than it does in enteric pathogens.

Keywords *Vibrio fischeri* · Symbiosis · Growth · *sapABCDF*

Introduction

The marine luminescent bacterium *Vibrio fischeri* is the specific light-organ symbiont of the Hawaiian bobtail squid, *Euprymna scolopes*. This cooperative association is initiated each generation when newly hatched juvenile squids collect an inoculum of their bacterial symbionts from the surrounding seawater (Nyholm et al. 2000). The ensuing colonization process can be divided into four distinct phases: (1) an initial infection phase in which *V. fischeri* cells enter the squid light organ and grow to a maximal colonization level of about 5×10^5 cells (0–12 h); (2) the expulsion of about 95% of the bacterial symbionts from the light organ triggered by a light stimulus at sunrise (~12 h); (3) re-growth of the remaining *V. fischeri* cells to their maximal colonization level (12–18 h) and, (4) persistence in a stationary phase (18–36 h) (Ruby and Asato 1993; Boettcher et al. 1996). The last three phases repeat on a daily basis throughout the life of the host, creating a complex and dynamic cycle of bacterial growth in the symbiosis.

Each of the symbiotic partners can be easily maintained in the laboratory, and molecular techniques that allow the genetic manipulation of *V. fischeri* have been developed. These characteristics, mono-specificity, horizontal transfer of the bacterial partner, and availability of genetic tools, make this symbiosis an ideal model system to study cooperative microbe-host interactions on a molecular level (Ruby 1996, 1999). Using this system, several bacterial genes have been identified that are required for *V. fischeri* to: (1) initiate the symbiosis (Graf et al. 1994; Visick and Skoufos 2001; Millikan and Ruby 2002); (2) attain a normal level of colonization (Graf and Ruby 1998; Aeckersberg, et al. 2001); (3) establish a persistent colonization (Graf and Ruby 2000; Visick et al. 2000); and (4) compete effectively with the wild-type parent strain (Visick and Ruby 1998).

The *sapABCDF* (*sap*=sensitive to antimicrobial peptides) genes were originally discovered in the intracellular pathogen *Salmonella typhimurium*. A transposon mutant

C. Lupp · E.G. Ruby (✉)
University of Hawaii, Kewalo Marine Laboratory,
41 Ahui Street, Honolulu, HI 96813, USA
e-mail: eruby@hawaii.edu,
Tel.: +1-808-5397311. Fax: +1-808-5994817

R.E.W. Hancock
University of British Columbia,
300–6174 University Blvd. Vancouver, BC Canada V6T 1Z3

library of *S. typhimurium* was screened with the antimicrobial peptide protamine, and mutants with insertions in either the *sapC* or *sapD* gene were found to have an enhanced susceptibility to protamine and to be less virulent (Groisman et al. 1992). It was later shown that a strain with a mutation in a *sapA* homologue of the plant pathogen *Erwinia chrysanthemi* showed a similar phenotype: its susceptibility to plant-derived antimicrobial peptides was increased, and its virulence was greatly reduced (Lopez-Solanilla et al. 1998, 2001). Recently, a transposon mutagenesis approach was used to identify four *Proteus mirabilis* mutants with an enhanced susceptibility to the antimicrobial peptide polymyxin B; one of these mutants carried the transposon in a gene homologous to *sapD* of *S. typhimurium* and *Erwinia chrysanthemi* (McCoy et al. 2001).

Other physiological defects have been ascribed to *sap* mutants of enteric bacterial species. A mutation in the *Escherichia coli trkE* (*sapDF*) locus conferred both reduced rate of potassium uptake and a reduced growth rate under potassium-limiting conditions. However, these changes in growth and potassium-transport kinetics were different from the ones produced by mutations in other *trk* genes (Bossemeyer et al. 1989; Dosch et al. 1991). A subsequent study of an *E. coli* $\Delta trkE$ mutant concluded that resistance to protamine is actually dependent on the ability of the cell to take up potassium, rather than on having a functional SapABCDF system (Stumpe and Bakker 1997). In contrast, while *Vibrio alginolyticus* also possesses a Trk potassium uptake system, the transport of potassium by this bacterium is apparently independent of *sapDF* (Nakamura et al. 1998; Harms et al. 2002).

As part of an unrelated study, a 500-bp fragment of *V. fischeri* ATCC 7744 genomic DNA was found to contain two partial ORFs with sequence similarity to the *sapD* and *sapF* genes of various species (Chen et al. 2000). The goal of this study was to investigate the function of the *sapABCDF* locus in the *V. fischeri*-*E. scolopes* symbiosis by: (1) locating, cloning and sequencing the genes, (2) constructing a *sapABCDF* null mutant, and (3) determining its phenotype in culture and in the host.

Materials and methods

Bacterial strains and growth conditions

Strains and plasmids used in this study are listed in Table 1. The symbiotic *V. fischeri* strain ES114 and its derivatives were grown at 28°C either in a seawater-based nutrient (SWT) medium (Boettcher and Ruby 1990) or Luria-Bertani Salt (LBS) medium (Graf et al. 1994). *Escherichia coli* strains were grown at 37°C in Luria-Bertani medium (LB) (Sambrook et al. 1989). Media were solidified with 1.5% (w/v) agar as needed. Antibiotics were added to the media at the following levels, when appropriate: chloramphenicol (Cam, 2 µg/ml for *V. fischeri*, 20 µg/ml for *E. coli*), kanamycin (Kan, 100 µg/ml for both *V. fischeri* and *E. coli*). For certain growth studies, a defined, artificial seawater-based minimal medium (MM) was used that contained 300 mM NaCl, 50 mM MgSO₄, 10 mM CaCl₂, 10 mM KCl, 0.01 mM FeSO₄, 50 mM Tris-HCl, pH 7.4, with either 0.33 mM K₂HPO₄ or 0.33 mM glycerol 2-phosphate as a phosphate source. The carbon and nitrogen sources were either 20 mM ribose and 0.3% casamino acids, 20 mM ribose and 10 mM NH₄Cl, or 20 mM *N*-acetyl-D-glucosamine. Medium reagents were purchased from Difco (Sparks, Md.) and Sigma (St. Louis, Mo.).

Table 1 Strains and plasmids used in this study

Strains and plasmids	Characteristics	Reference or source
<i>Escherichia coli</i> strains		
DH5 α	Cloning strain	(Stabb et al. 2001)
CC118 λ pir	Host strain for plasmid pEVS104	(Visick and Ruby 1997)
<i>Vibrio fischeri</i> strains		
ES114	<i>V. fischeri</i> wild-type isolate from <i>E. scolopes</i> light organ	(Boettcher and Ruby 1990)
CL10	<i>V. fischeri</i> <i>sapA</i> mutant; <i>sapA</i> gene disrupted by <i>kanR</i> marker	This study
CL16	CL10 that has been reverse-complemented (<i>sapA</i> ⁺)	This study
Plasmids		
pEVS79	Allelic exchange vector	(Stabb and Ruby 2003)
pEVS104	Conjugal helper plasmid	(Stabb and Ruby 2003)
pLS6	<i>V. fischeri</i> cloning vector, carrying a chloramphenicol-resistance marker (<i>camR</i>)	(Visick and Ruby 1997)
PCR2.1	PCR-product cloning vector	Invitrogen
pUC4 K	Origin of the kanamycin-resistance marker (<i>kanR</i>)	(Messing and Vieira 1982)
pCL103	pEVS79 with a 5.9-kb <i>Xba</i> I- <i>Spe</i> I fragment carrying the <i>V. fischeri</i> ES114 <i>sapABCDF</i> locus, 900 bp of upstream and 700 bp of downstream sequence	This study
pCL105	pEVS79 with a 3.7-kb <i>Xba</i> I- <i>Sac</i> I fragment carrying the <i>V. fischeri</i> ES114 <i>sapA</i> , <i>sapB</i> and partial <i>sapC</i> genes, and 900 bp of upstream sequence	This study
pCL109	pCL105 with a <i>kanR</i> insertion at the <i>Nsi</i> I site in the <i>sapA</i> gene	This study
pCL110	pLS6 with a 6.0-kb <i>Bgl</i> II- <i>Eae</i> I fragment from <i>V. fischeri</i> ES114 genomic DNA carrying the <i>sapABCDF</i> locus with 600 bp of upstream and downstream sequence	This study
pCL111	pLS6 with a 2.4-kb <i>Bgl</i> II- <i>Hpa</i> I fragment from <i>V. fischeri</i> ES114 genomic DNA, carrying <i>sapA</i> with 600 bp of upstream sequence and a partial <i>sapB</i> sequence	This study

Fig. 1A–D The *Vibrio fischeri* *sapABCD* locus. The *V. fischeri* *sapABCD* genes were cloned on plasmid pCL103 (A) carrying a 6.9-kb *Xba*I-*Spe*I chromosomal fragment. The *sapA* mutant was constructed by homologous recombination using the plasmid pCL109 (B), which carries a *kanR* cassette inserted into the *Nsi*I site, disrupting the *sapA* gene 900 bp downstream of the predicted transcriptional start site. Plasmids pCL110 (C) and pCL111 (D), carrying *sapABCD* and *sapA*, respectively, as well as 600 bp of upstream sequence, were used in complementation studies

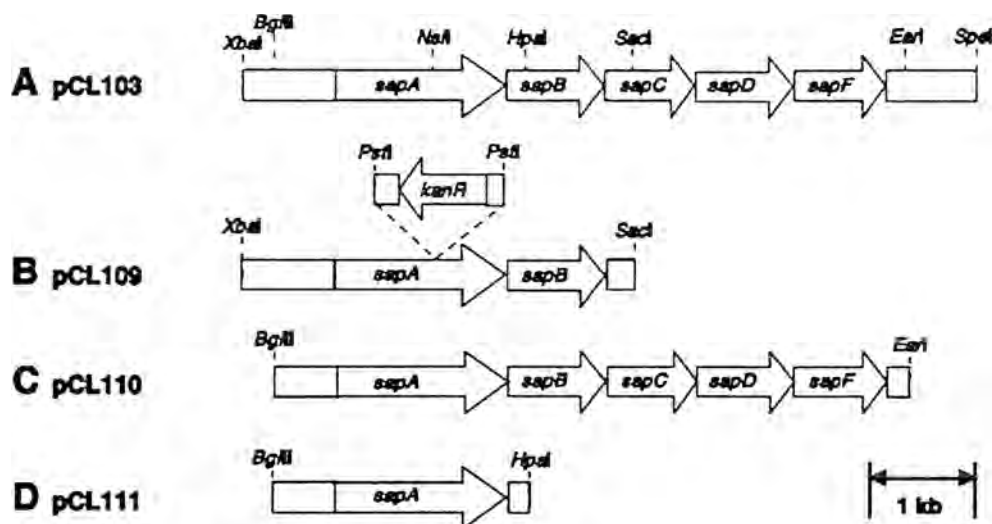

Genetic techniques

Genomic and plasmid DNA were extracted using Qiagen DNeasy and Qiaprep Miniprep systems (Qiagen, Valencia, Calif.), respectively. PCR was carried out according to standard protocols (Sambrook et al. 1989) using AmpliTaq DNA polymerase (Perkin-Elmer, Branchburg, N.Y.). For plasmid constructions, restriction enzymes and DNA ligase were obtained from New England Biolabs (Beverly, Mass.) and used according to the manufacturer's protocols. Transfer of plasmids into *E. coli* host strains was accomplished using standard techniques (Sambrook et al. 1989). Triparental conjugation was used to transfer plasmids into *V. fischeri* strains (Stabb et al. 2001). A Perkin-Elmer/ABI Prism automated sequencer was used (University of Hawaii Biotechnology/Molecular Biology Instrumentation and Training Facility).

Cloning and sequencing of the *V. fischeri* *sapABCD* locus

A 420-bp fragment of *V. fischeri* ES114 genomic DNA containing partial gene sequences of *sapD* and *sapF* was amplified by PCR using the primers 5' TTACCCATTGGTTGTCG 3' and 5' GGATCCTGGAAAATCAT 3'. The primer sequence was based on a previously published 480-bp sequence of the *V. fischeri* strain ATCC 7744 (Chen et al. 2000). The resulting PCR product was used as a template to create a digoxigenin-labeled Southern hybridization probe (PCR DIG labeling kit, Boehringer Mannheim). Genomic DNA obtained from *V. fischeri* ES114 was digested with different restriction enzymes, separated on a 1% agarose gel, transferred to a nylon membrane (Hybond-N+, Amersham Pharmacia Biotech, Piscataway, N.J.) and hybridized with the probe, which was detected using CDP-Star Chemi-Luminescence substrate (Boehringer Mannheim). A 6.9-kb fragment containing the target sequence was identified and isolated from a *Xba*I-*Spe*I restriction digest of genomic DNA, and cloned into the mobilizable vector pEV579. The clone containing pCL103 (Fig. 1 A) was identified by dot-blot hybridization, and both strands of the insert were sequenced by primer-walking. Sequence analysis was carried out using the software programs Vector NTI Suite 5.5 (InforMax, North Bethesda, MD) and BLAST (<http://www.ncbi.nlm.nih.gov/BLAST/>). Sequences other than those from *V. fischeri* were obtained from GenBank (*S. typhimurium*, *E. chrysanthemi*, *E. coli*) and TIGR (*Vibrio cholerae*).

Construction of a *sapA* mutant and complementing strains

A 3.4-kb fragment of pCL103 was subcloned by digestion with *Sac*I and religation, producing pCL105 (Table 1). A kanamycin-re-

sistance marker was isolated from pUC4K by restriction digest with *Pst*I, and ligated into the *Nsi*I site of pCL105. The resulting plasmid pCL109 (Fig. 1B) was transferred into *V. fischeri* ES114 by triparental mating, and single- and double-recombinants were selected as previously described (Stabb et al. 2001), generating the *V. fischeri* *sapA* mutant strain CL10.

The *sapA* mutant was complemented *in trans* with either the complete *sapABCD* locus or with the *sapA* gene only. A 6.0-kb *Bgl*II-*Ear*I fragment carrying the *sapABCD* locus and a 2.4-kb *Bgl*II-*Hpa*I fragment carrying only the *sapA* gene were each isolated from pCL103, gel-purified, and ligated into the vector pLS6 (Table 1). The resulting plasmids, pCL110 and pCL111 (Fig. 1C, D), as well as the vector control pLS6, were transferred into both wild-type *V. fischeri* and the *sapA* mutant CL10 (Table 1). Because the addition of antibiotics to maintain the complementing plasmids was not practical in some experiments, the *sapA* mutant was also reverse-complemented by recombining the plasmid pCL105, which carries the wild-type *sapA* gene, into the genome of the *sapA* mutant strain CL10 by triparental mating. The resulting strain CL16, a double-recombinant that had become restored with a functional *sapA*, was identified by its kanamycin sensitivity; the loss of the *kanR* marker was further confirmed by PCR analysis of the *sapA* gene locus.

Growth characteristics

To determine the growth characteristics of *V. fischeri* wild-type, the *sapA* mutant, and the complemented *sapA* mutant strains in media of different compositions, 10 ml of each medium were inoculated to an optical density (OD) at 600 nm of about 0.05 with cells that had been pre-grown in this medium. Cultures were kept shaking at 28 °C, samples were taken during the exponential growth phase at different times, and the ODs were measured and plotted against time. Regression analyses of the resulting growth curves were carried out using MiniTab 10 Xtra (MiniTab Inc. State College, Penn.), and generation times were calculated from the slope of the exponential regression line during exponential growth. To determine the growth yield, the cultures were incubated for a total of 24 h and the final OD was measured.

Colonization assays

Four assays were used to determine the colonization phenotype of wild-type *V. fischeri*, the *sapA* mutant, and their derivatives.

Bioluminescence assay

The course of the early colonization events was monitored as previously described (Ruby and Asato 1993). Briefly, newly hatched squids were placed into vials with 4 ml of filter-sterilized seawater containing an inoculum of approximately 4,000 colony forming units (CFU) of either wild-type *V. fischeri*, the *sapA* mutant, or the reverse-complemented *sapA* mutant. Thirty-six individual animals were infected per treatment group; 12 animals served as an uninoculated control and were placed into filter-sterilized seawater without added bacteria. Bioluminescence of the animals, an indirect measure of the degree of colonization of the squids, was monitored periodically over 24 h using an automated photometer.

Level of colonization in the squid light organ

The number of CFU per squid was determined at 12, 20, and 48 h post-inoculation as previously described (Ruby 1996). Briefly, newly hatched squids were placed into 50 ml of filter-sterilized seawater containing about 50,000 CFU of either wild-type *V. fischeri*, the *sapA* mutant, or the reverse-complemented *sapA* mutant, and incubated for 12 h. Some animals were placed in filter-sterilized seawater without added bacteria. At each of the time points, 15 animals per treatment group and two uninoculated animals were homogenized, and the homogenate was diluted and spread onto SWT agar. The *V. fischeri* colonies arising after an overnight incubation were counted, and the number of CFU per squid calculated.

Minimum infectious dose

Individual, newly hatched squids were placed into 4 ml of filter-sterilized seawater containing 50, 100, 200 or 400 CFU of either wild-type *V. fischeri* or the *sapA* mutant. After an incubation period of 3 h, the squids were transferred to fresh vials with 4 ml of filter-sterilized seawater containing no added bacteria. Successful colonization was indicated by the presence of animal luminescence at 48 h as detected with a TD-20/20 luminometer (Turner Design, Sunnyvale, Calif.).

Competitive phenotype

The presence of a competitive colonization advantage of either wild-type *V. fischeri* or the *sapA* mutant strain was determined as previously described (Visick and Ruby 1998) with the following modifications. Briefly, about 15 newly hatched squid were placed into 50 ml of filter-sterilized seawater, containing approximately 50,000 CFU of each of the competing strains, and incubated for 12 h. A sample of the inoculated seawater was spread onto LBS agar to determine the exact ratio of the two strains in the inoculum. At 24 h post-inoculation, squid were homogenized and a dilution of the homogenate spread onto LBS agar. About 100 CFU from both the inoculum and the homogenates were patched onto antibiotic-containing and antibiotic-free LBS agar to determine the ratio of wild-type *V. fischeri* (kanamycin-sensitive) to *sapA* mutant (kanamycin-resistant).

Stress response assays

Four assays were used to determine the effects of a *sapA* mutation on the resistance of the bacterium to agents of cellular stress.

Antimicrobial peptides

The minimal inhibitory concentration (MIC) for each of eight cationic antimicrobial peptides, CP11CN, CP26, CP28, CP29, LL37, P-CN, polymyxin sulfate, and protamine sulfate (Friedrich et al. 1999, 2000; Jia et al. 2000; Travis et al. 2000), was determined using a modified microtiter broth-dilution method (Jia et al.

2000). Briefly, a solution of each peptide was diluted by serial two-fold dilutions in distilled water containing 0.01% acetic acid and 0.2% bovine serum albumin. Bacterial cultures in mid-exponential growth phase were diluted to a concentration of about 1×10^5 cells per ml of LBS, and 200 μ l of the culture were placed into 96-well microtiter dishes, to which 22 μ l of the peptide dilutions were added. The dish was incubated with shaking at 22 °C for 16–20 h, during which time the OD of each of the cultures was periodically measured using a Perkin-Elmer HTS 7000 BioAssay plate reader. The MIC was defined as the concentration of the peptide that resulted in a 50% decrease in maximal growth rate. In each of the assays, the *V. fischeri* strain *ompU* (Aeckersberg et al. 2001) was used as a positive control.

Detergent exposure

The MIC of SDS and dioxycholate were determined by the modified microtiter-broth dilution method as described above for the antimicrobial peptide resistance assay.

Heat shock

Mid-exponential phase SWT cultures of wild-type *V. fischeri* or the *sapA* mutant were diluted to a concentration of about 5,000 cells per ml in fresh medium, and aliquots of these cultures were placed in a 42 °C water bath. After different exposure times (no exposure, 10 s, 30 s, 1 min, 2 min, 5 min, 10 min and 20 min), 50 μ l of the cultures were spread on SWT agar. After an overnight incubation at 28 °C, CFU were determined, normalized to the unexposed control, and plotted against the exposure time to estimate the time required to kill 50% of the cells.

Osmotic shock

Mid-exponential phase SWT cultures of wild-type *V. fischeri* or the *sapA* mutant were diluted to a concentration of about 2.5×10^7 cells per ml of SWT medium. A 10- μ l aliquot of the diluted culture was transferred into 490 μ l of sterile distilled water containing (per ml) 0, 2.5, 5, 10, 15, 20, 25, 35, 50, 75 or 100 mg of NaCl. After a 10-min incubation, 10 μ l were diluted into 990 μ l of sterile seawater, and 50 μ l of the dilution spread onto SWT agar. CFU were determined after an overnight incubation at 28 °C and normalized to the unexposed positive control to estimate the NaCl concentration required to kill 50% of the cells.

Sequence accession number

The sequence of the *sapABCD* locus has been submitted to GenBank under the accession number: AF454370.

Results

The *sapABCD* locus in *V. fischeri* is homologous to *sap* loci in other species

To characterize the *V. fischeri* ES114 *sapABCD* locus, a 6.9-kb *Xba*I-*Spe*I genomic DNA fragment containing the *sap* genes, as well as several hundred base pairs of flanking sequence, was cloned and sequenced (Fig. 1A). The locus has the same gene arrangement as the homologous *sapABCD* loci of *V. cholerae*, *S. typhimurium*, *E. chrysanthemi* and *E. coli*. The predicted *V. fischeri* Sap proteins are most closely related to those of *V. cholerae*. The SapD and SapF proteins, homologs of the cytoplas-

mic ATPases of the ABC transporter family, exhibit the highest similarity among all the species. Conserved ATP-binding motifs (Walker et al. 1982), which are the characteristic functional domains of ATPases, were identified at amino acids 40–55 and 169–184 in SapD, and at amino acids 47–62 and 161–176 of SapF in *V. fischeri*.

The *sapABCDF* genes have been shown to be transcribed as a single transcript in *S. typhimurium* (Parra-Lopez et al. 1993), and sequence analyses suggested that the same polycistronic operon structure is present in *V. fischeri*. Specifically, a strong transcriptional terminator was found downstream of the *V. fischeri sapF* gene, while none was detected within the *sapABCDF* locus. In addition, the locus contains overlapping start- and stop-codons; i.e., there are no intergenic regions.

The growth rate of the *V. fischeri sapA* insertion mutant is reduced

Because of its apparent operon structure, the strategy chosen to create a *sapABCDF* null mutant strain was to insert a kanamycin-resistance (*kanR*) marker into the *sapA* gene. A clone was obtained that carried a 3.7-kb *XbaI-SacI* fragment comprising 0.9 kb of upstream sequence, as well as complete *sapA* and *sapB*, and partial *sapC* sequences. The *kanR* marker was inserted 900 bp downstream of the putative transcriptional start site of the *sapA* gene in this clone, producing pCL109 (Fig. 1B). The *V. fischeri sapA* mutant strain CL10 was obtained by homologous recombination of pCL109 into the chromosome of strain ES114 (Table 1). Insertion of the *kanR* marker into the expected location of the genome was confirmed by Southern-blot analysis. Its orientation was opposite that of the *sapA* gene as determined by sequencing the flanking region of the insert using primers from sites within the *kanR* gene (data not shown). Control experiments performed in another study have shown that carriage of this *kanR* gene has no detectable effect on the growth of *V. fischeri* cells either in culture or in the symbiosis (Stabb and Ruby, personal communication).

After an overnight incubation at 28 °C on nutrient agar, the *V. fischeri sapA* mutant produced colonies that were visibly smaller than the wild-type strain. To further investigate this observation, we determined the generation times of both *V. fischeri* wild type and the *sapA* mutant carrying *in trans*: (1) no complementing plasmids, (2) pLS6, the vector control, (3) pCL111, the vector containing *sapA*, or (4) pCL110, the vector containing *sapABCDF* (Table 1; Fig. 1C, D). None of the strains displayed a lag phase, but the *V. fischeri sapA* mutant grew significantly more slowly than the wild-type strain, except when it was complemented by the entire *sapABCDF* locus (Fig. 2A, B). Thus, the *sapA* mutation appears to have a polar effect on the expression of one or more of the downstream *sap* genes. Interestingly, the final growth yields of all of the strains were the same, indicating that in culture medium the *sap* mutation does not limit the extent of growth (Fig. 2A, and data not shown).

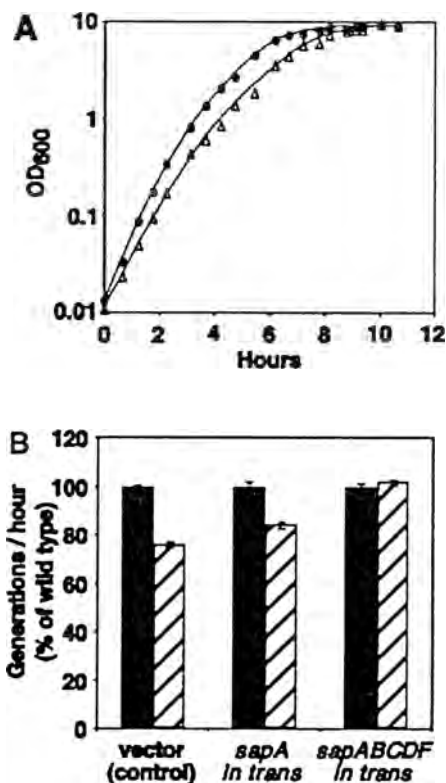

Fig. 2A, B Relative growth rates of *V. fischeri* wild type, *sapA* mutant and complemented *sapA* mutant strains. **A** Growth curves of *V. fischeri* wild-type strain ES114 (closed circles) and the *sapA* mutant CL10 (open triangles) grown in SWT medium. Maximum growth rates were determined on the early exponential portion of the curves (usually the first 2 h). **B** The *V. fischeri* wild-type (black bars), and the *sapA* mutant (hatched bars) were grown either: (1) carrying the vector plasmid (control), (2) carrying the vector containing *sapA*, or (3) carrying the vector containing *sapABCDF*. The generation times were determined in LBS medium containing 2 μ g of chloramphenicol per ml. Presented are the results of a single experiment, normalized to wild-type levels, but each experiment was repeated at least once with the same outcome. Error bars Standard error of the slope of the growth-rate regression line obtained from each culture

These complementation data provide evidence that the observed reduction of growth rate is due to the interruption of *sapA* and not to a secondary effect, such as the expression of a truncated SapA protein, a secondary mutation elsewhere in the genome, or a downstream effect on genes outside the putative *sapABCDF* operon. The observation that complementation with *sapA* alone did not restore the wild-type phenotype also supports the hypothesis that the *sapABCDF* genes are co-transcribed.

The *V. fischeri sapA* mutant is less effective in colonizing the host squid

The initial events in the colonization process of *E. scolopes* by either *V. fischeri* wild type, the *sapA* mutant, or the reverse-complemented *sapA* mutant were monitored for the first 24 h post-inoculation (Fig. 3). The time that light emission is first detectable, which is a function of both

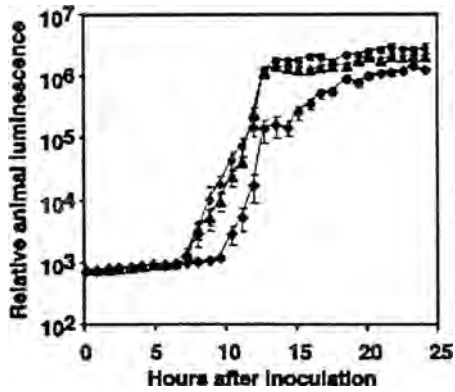

Fig. 3 Development of bioluminescence in squids during colonization by *V. fischeri* strains. Newly hatched juveniles of *E. scolopes* were incubated with either *V. fischeri* wild-type strain ES114 (circles), the *sapA* mutant CL10 (diamonds), or the reverse-complemented *sapA* mutant CL16 (triangles). Animal bioluminescence was detected as a measure of the degree of colonization. Each data point represents the average bioluminescence level of 36 animals, with the indicated standard errors of the mean. The luminescence of uninoculated animals was equal to the background level (data not shown). The same results were obtained when the experiment was repeated

bacterial population size and autoinducer concentration (Boettcher and Ruby 1990), was delayed by about 2 h in animals colonized by the *sapA* mutant, and the level of light produced was generally lower thereafter. The colonization phenotype of the *sapA* mutant could be complemented by reverse complementation, demonstrating that the observed phenotype is a result of the mutation on the *sap* locus and not due to any secondary effect. Because luminescence is only an indirect measure of the degree of colonization, the number of *V. fischeri* CFU per light organ was also determined at 12, 20 and 48 h post-inoculation (Table 2). These data confirmed that the number of symbionts is significantly lower at 12 h and 24 h in animals colonized by the *sapA* mutant, and that this decreased level of colonization by the *sapA* mutant continues for at least 48 h post-inoculation.

A possible explanation for the delay in colonization was that the *sapA* mutant requires a higher level of inoculum than the wild-type strain. However, for both the wild-type and the *sapA* mutant strains the minimal inoculum that resulted in colonization of 50% of the animals under the standard assay conditions was about 100 CFU per animal (data not shown).

Table 2 Colonization effectiveness of *Vibrio fischeri* strains. The number of CFU per squid of *V. fischeri* wild-type, the *sapA* mutant, and the reverse-complemented *sapA* mutant was determined at 12, 20 and 48 h post-inoculation. The values represent the mean

Inoculating strain	CFU per light organ ($\times 10^4$) at:		
	12 h	20 h	48 h
ES114 (wild-type)	0.21 (± 0.033)	12.8 (± 1.9)	9.1 (± 1.3)
CL10 (<i>sapA</i> mutant)	0.02 (± 0.003)	2.4 (± 0.9)	6.0 (± 1.2)
CL16 (reverse-complemented <i>sapA</i> mutant)	Not determined	14.9 (± 3.2)	13.5 (± 1.7)

The competitive phenotype of the *sapA* mutant was examined to determine whether there was evidence that a factor other than its growth defect might contribute to the observed colonization phenotype. Newly hatched squids were incubated with a mixed inoculum consisting of an equal proportion of wild-type *V. fischeri* and *sapA* mutant cells, and the ratio of the two strains was determined in the resulting light organ population 24 h post-inoculation (Fig. 4). The *sapA* mutant was significantly reduced in its ability to compete with the wild-type strain during colonization: the ratio of *V. fischeri sapA* mutant to wild-type decreased by a factor of >15 in the light organ as soon as 24 h post-inoculation. In contrast, genetic complementation with the *sapABCD* genes *in trans* allowed the *sapA* mutant to compete well with the wild-type strain, essentially maintaining its inoculation ratio during growth in the light organ.

The growth defect of the *sapA* mutant is not related to either the concentration of potassium or the source of carbon, nitrogen, or phosphorus in the medium

It has been reported that a mutation in the *sapDF* (*trkE*) genes confers a potassium-dependent growth defect on *E. coli* cells (Dosch et al. 1991). Therefore, we compared the growth rates of the *V. fischeri sapA* mutant and the wild-type strain in minimal medium containing 0.1, 1, 10 or 100 mM potassium chloride. Neither strain grew in medium with a potassium ion concentration of 0.1 mM or less. However, the relative growth rates of the mutant and the wild-type were the same at the other three potassium concentrations (data not shown), indicating that the growth defect of the *sapA* mutant is unlikely to be due to potassium starvation.

In an attempt to identify a possible substrate for the putative Sap transporter, the growth rates of wild-type *V. fischeri* and the *sapA* mutant were compared in defined minimal media containing different compounds as sole carbon, nitrogen, or phosphorous sources. We reasoned that if the *sap* locus encodes a permease system for a specific form of one of these nutrients, then the *sapA* mutant might have a relative growth defect in medium that contained this substrate as the sole source of an essential chemical element; however, there should be no such defect when this substrate was replaced by a chemically distinct source of the element. Because the carriage of com-

(\pm standard error of the mean) of 15 animals per treatment, for each time point after inoculation; no CFU could be detected in light organs of animals that were maintained in uninoculated seawater

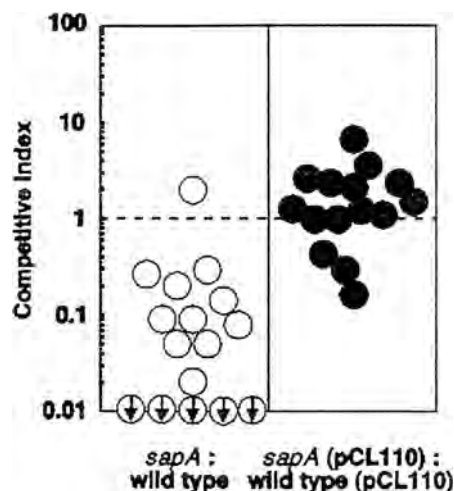

Fig. 4 Colonization phenotype of the *sapA* mutant when competed against the wild-type strain. Juvenile animals were incubated with an approximately 1:1 ratio of either the *sapA* mutant CL10 and the wild-type strain ES114 (open circles) or the *sapA* mutant and the wild-type strain, each carrying pCL110 *sapABCDEF* in trans (closed circles). At 24 h after inoculation, 100 bacterial colonies from the homogenate of each squid light organ were identified, and the ratio of mutant to wild-type cells in the population determined. Each circle represents the competitive index determined from an individual animal, expressed as the relative proportion of *sapA* mutant cells present in the light organ at 24 h post-inoculation. Circles with an arrow indicate animals with a competitive index below the detection level (<0.01). The experiments were repeated twice with the same results

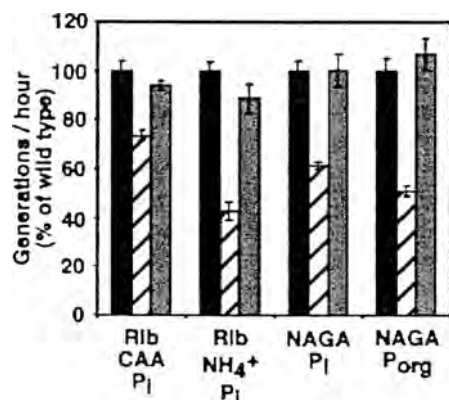

Fig. 5 Generation times of *V. fischeri* strains grown in media with different nutrient sources. *V. fischeri* wild-type strain ES114 (black bars), the *sapA* mutant CL10 (hatched bars), and the reverse-complemented *sapA* mutant CL16 (gray bars) were grown in minimal media containing: ribose (Rib) or *N*-acetyl-D-glucosamine (NAGA) as the carbon source; casamino acids (CAA), ammonia (NH_4^+) or NAGA as the nitrogen source; and inorganic phosphate (P_i) or glycerol 2-phosphate (P_{org}) as the phosphorous sources. Presented are the results of a single experiment, normalized to wild-type levels, with error bars indicating the standard error of the slope of the regression line for the growth curve in each medium type. Each growth curve was repeated at least once with the same result

plementing plasmids reduces the growth rate substantially in minimal medium, the reverse-complemented *sapA* mutant was used as a control in this set of experiments.

Regardless of the nature of the nutrient source tested, the *sapA* mutant grew more slowly than the wild-type strain (Fig. 5); however, there was no detectable difference in the final growth yield (data not shown). Reverse complementation could restore the wild-type growth rate in each case. Each of the classes of elemental nutrients (C, N or P) could be excluded as being the source of a limiting substrate for the possible transporter because substitution with a different chemical form of the element did not relieve the growth-rate defect of the *sapA* mutant.

The SapABCDEF proteins also do not appear to be involved in the transport of iron because the addition of a high concentration (100 μM) of Fe^{3+} to LBS medium had no effect on the growth rate of either the *V. fischeri sapA* mutant strain or wild type (data not shown).

The *V. fischeri sapA* mutant withstands cell-membrane stress agents normally

While light microscopy revealed no differences in cell morphology between the wild-type and the *sapA* mutant strain, it remained possible that the reduced growth rate of the mutant was caused by a general membrane disturbance resulting from the absence of the putative cytoplasmic membrane proteins SapB and SapC. To explore this possibility, we investigated the responses of *V. fischeri* wild-type and the *sapA* mutant to four different stress conditions that target membrane integrity: cationic peptides, detergents, heat, and osmolarity.

The presence of functional *sap* genes has been implicated in the ability of enteric bacteria to withstand cationic antimicrobial peptides (Parra-Lopez et al. 1993; Lopez-Solanilla et al. 1998). Thus, for wild-type *V. fischeri* and the *sapA* mutant strain, the MICs of a variety of cationic antimicrobial peptides with diverse amino acid sequences and structures were determined. Although there were differences between the actual values of the MICs for wild-type *V. fischeri* and for *Vibrio anguillarum* or *S. typhimurium* (Jia et al. 2000), the relative levels of sensitivities to the eight peptides were generally the same under our assay conditions (data not shown). Most significantly, for each of the tested peptides, the MICs were identical for the *sapA* mutant and wild-type *V. fischeri*, suggesting that a functional SapABCDEF system in *V. fischeri* does not confer an increased resistance to antimicrobial peptides. The *V. fischeri* strain *ompU*, which was used as a control in these experiments, displayed an enhanced susceptibility to each of these peptides. Similarly, under each of the other three stress conditions tested, there was no significant difference between the responses of wild-type *V. fischeri* and the *sapA* mutant during growth or in survival of stationary phase (data not shown).

Discussion

The *sapABCDEF* genes in the pathogenic bacterial species *S. typhimurium* and *E. chrysanthemi* have been reported

to contribute to the ability of these bacteria to colonize their hosts (Parra-Lopez et al. 1993; Lopez-Solanilla et al. 1998). A recently published 500-bp genomic sequence from the *V. fischeri* strain ATCC 7744 that had a high level of identity to the 3' end of the *sapD* gene and the 5' end of the *sapF* gene (Chen et al. 2000) indicated that these genes might be present in this species as well. If they were, we reasoned that it would be of interest to know whether the *V. fischeri* *sap* locus encodes functions that might be important in the symbiotic colonization of the light organ of the Hawaiian bobtail squid, *E. scolopes*.

We identified and cloned the *sapABCDF* locus of *V. fischeri* strain ES114, and its sequence revealed high similarity to these genes in other bacteria. A *V. fischeri* *sapA* mutant was constructed and its growth and symbiotic colonization phenotypes were compared with those of the wild-type strain. As has been reported for a *E. chrysanthemi* *sapA* deletion mutant (Lopez-Solanilla et al. 1998), and *S. typhimurium* *sapC* and *sapD* transposon mutants (Groisman et al. 1992), the *V. fischeri* *sapA* mutant is less effective at colonizing its host. During its colonization of the light organ, *V. fischeri* attains a sufficient population density to induce bioluminescence, which increases to a maximum level at about 12 h post-inoculation (Ruby and Asato 1993). The times at which luminescence is first detected and at which it reaches a maximum are both delayed in squids that are colonized by the *sapA* mutant. However, because the *V. fischeri* *sapA* mutant also displays a growth-rate defect in culture (Fig. 1), explanation of any defect in colonization rate does not require a specific role of the *sap* operon in symbiosis.

At each of three times during the first 48 h of colonization, there were fewer bacteria in animals colonized by the *sapA* mutant than by the wild-type (Table 2). This result indicates that not only the rate but also the extent of colonization by the *sapA* mutant is significantly impaired. Because the growth yield of the *sapA* mutant is unaffected in culture medium, there is no simple explanation for its failure to reach a normal level of colonization in the host, suggesting that the yield defect may be specific to the conditions of the symbiosis. This phenotype is similar to that reported for certain auxotrophic mutants of *V. fischeri* (Graf and Ruby 1998) and indicates that the *sap* locus may play an analogous, but as yet unknown, function when the symbionts are colonizing the host light organ.

Little is known about the physiological effects caused by *sap* gene mutations in other bacteria. Because an *E. coli* *sapD* mutant (also called Δ *trkE*) grows more slowly under potassium-limiting conditions, a link between the *sap* genes and potassium transport has been proposed (Bossemeyer et al. 1989; Dosch et al. 1991; Harms et al. 2002). However, we detected no difference between the growth rates of the *V. fischeri* wild-type and the *sapA* mutant in media containing either low or high potassium concentrations. Thus, if the *V. fischeri* *sapA* mutation does disrupt the expression of the rest of the locus, then it appears that the *sapD* gene of this bacterium does not contribute to potassium transport in the same way as its homologue does in *E. coli*. It has been proposed that, unlike

E. coli, the *V. alginolyticus* Trk potassium-uptake system utilizes ATPase subunits from transporters other than the SapABCDF proteins (Nakamura et al. 1998; Harms et al. 2002). Thus, it is possible that in *Vibrio* species the Trk system is independent of *sapD*, which would explain the potassium-insensitive growth-rate defect of the *V. fischeri* *sapA* mutant. If, as proposed for *E. coli* (Stumpe and Bakker 1997), a sufficiency of potassium transport is integral to antimicrobial peptide resistance, then the *V. fischeri* *sapABCDF* genes may not contribute to antimicrobial peptide resistance because they are not required for potassium transport.

To better understand the physiological function of the *V. fischeri* SapABCDF proteins, the observed growth defect was investigated in more detail. Because of the growth-rate defect of the *V. fischeri* *sapA* mutant in tryptone-containing medium, as well as the sequence similarity of SapA to peptide transporters like DppA and OppA (Detmers et al. 2001), it seemed reasonable that the SapABCDF proteins might play a role in the nutritional uptake of peptides. However, the growth defect of the *sapA* mutant was also expressed in defined minimal media containing structurally distinct sources of carbon, nitrogen, and phosphorous (Fig. 5). Thus, it is unlikely that the SapABCDF proteins are required for the specific uptake of an external nutrient.

Similarly, under our assay conditions the responses of the *sapA* mutant to several stress conditions (i.e., cationic peptides, detergents, heat, and osmolarity) were indistinguishable from those of the wild-type strain, suggesting that the absence of the SapABCDF proteins does not create a general membrane defect in culture. Preliminary studies suggest that *E. scolopes* tissues produce antimicrobial peptides (W. Crookes and M. McFall-Ngai, Kewalo Marine Laboratory, University of Hawaii, personal communication). While the *sapA* mutant is not more sensitive to the cationic peptides tested in this study, it remains possible that the *V. fischeri* *sapA* mutant will prove to be more sensitive to such host peptides.

Acknowledgements We would like to thank E. Stabb for experimental help and advice, and D. Millikan for useful comments on the manuscript. This work was supported by the National Institutes of Health grant RR12294 to EGR and M. McFall-Ngai, by the National Science Foundation grant IBN 02-11673 to M. McFall-Ngai and EGR, and by a Cancer Research Center of Hawaii grant to CL.

References

- Aeckersberg F, Lupp C, Ruby EG (2001) *Vibrio fischeri* outer membrane protein OmpU plays a role in normal symbiotic colonization. *J Bacteriol* 183:6590-6597
- Boettcher KJ, Ruby EG (1990) Depressed light emission by symbiotic *Vibrio fischeri* of the sepiolid squid *Euprymna scolopes*. *J Bacteriol* 172:3701-3706
- Boettcher KJ, Ruby EG, McFall-Ngai MJ (1996) Bioluminescence in the symbiotic squid *Euprymna scolopes* is controlled by a daily biological rhythm. *J Comp Physiol* 179:65-73

- Bossemeyer D, Borchard A, Dosch DC, Helmer GC, Epstein W, Booth IR, Bakker EP (1989) K⁺-transport protein TrkA of *Escherichia coli* is a peripheral membrane protein that requires other Trk gene products for attachment to the cytoplasmic membrane. *J Biol Chem* 264:16403–16410
- Chen HY, Weng SF, Lin JW (2000) Identification and analysis of the *sap* genes from *Vibrio fischeri* belonging to the ATP-binding cassette gene family required for peptide transport and resistance to antimicrobial peptides. *Biochem Biophys Res Commun* 269:743–748
- Detmers JM, Lanfermeijer FC, Poolman B (2001) Peptides and ATP binding cassette peptide transporters. *Res Microbiol* 152: 245–258
- Dosch DC, Helmer GL, Sutton SH, Salvacion FF, Epstein W (1991) Genetic analysis of potassium transport loci in *Escherichia coli*: evidence for three constitutive systems mediating uptake of potassium. *J Bacteriol* 173:687–696
- Friedrich C, Scott MG, Karunaratne N, Yan H, Hancock REW (1999) Salt-resistant alpha-helical cationic peptides. *Antimicrob Agents Chemother* 43:1542–1548
- Friedrich CL, Moyles D, Beveridge TJ, Hancock REW (2000) Antibacterial action of structurally diverse cationic peptides on Gram-positive bacteria. *Antimicrob Agents Chemother* 44: 2086–2092
- Graf J, Ruby EG (1998) Host-derived amino acids support the proliferation of symbiotic bacteria. *Proc Natl Acad Sci USA* 95: 1818–1822
- Graf J, Ruby EG (2000) Novel effects of a transposon insertion in the *Vibrio fischeri glnD* gene: defects in iron uptake and symbiotic persistence in addition to nitrogen utilization. *Mol Microbiol* 37:168–179
- Graf J, Dunlap PV, Ruby EG (1994) Effect of transposon-induced motility mutations on colonization of the host light organ by *Vibrio fischeri*. *J Bacteriol* 176:6986–6991
- Groisman EA, Parra-Lopez C, Salcedo M, Lipps CJ, Heffron F (1992) Resistance to host antimicrobial peptides is necessary for *Salmonella* virulence. *Proc Natl Acad Sci USA* 89:11939–11943
- Harms C, Domoto Y, Celik C, Rahe E, Stumpe S, Schmid R, Nakamura T, Bakker EP (2002) Identification of the ABC protein SapD as the subunit that confers ATP dependence to the K⁺-uptake systems Trk^H and Trk^G from *Escherichia coli* K-12. *Microbiology* 147:2991–3003
- Jia X, Patrzykat A, Devlin RH, Ackerman PA, Iwama GK, Hancock REW (2000) Antimicrobial peptides protect coho salmon from *Vibrio anguillarum* infections. *Appl Environ Microbiol* 66:1928–1932
- Lopez-Solanilla E, Garcia-Olmedo F, Rodriguez-Palenzuela P (1998) Inactivation of the *sapA* to *sapF* locus of *Erwinia chrysanthemi* reveals common features in plant and animal bacterial pathogenesis. *Plant Cell* 10:917–924
- Lopez-Solanilla E, Llama-Palacios Collmer AA, Garcia-Olmedo F, Rodriguez-Palenzuela P (2001) Relative effects on virulence of mutations in the *sap*, *pel* and *hrp* loci of *Erwinia chrysanthemi*. *Mol Plant Microbe Interact* 14:386–393
- McCoy AJ, Liu H, Falla TJ, Gunn JS (2001) Identification of *Proteus mirabilis* mutants with increased sensitivity to antimicrobial peptides. *Antimicrob Agents Chemother* 45:2030–2037
- Messing J, Vieira J (1982) A new pair of M13 vectors for selecting either DNA strand of double-digest restriction fragments. *Gene* 19:259–268
- Millikan D, Ruby EG (2002) Alterations in *Vibrio fischeri* motility correlate with a delay in symbiosis initiation and are associated with additional symbiotic colonization defects. *Appl Environ Microbiol* 68:2519–2528
- Nakamura T, Yamamuro N, Stumpe S, Unemoto T, Bakker EP (1998) Cloning of the *trkAH* gene cluster and characterization of the K⁺-uptake system of *Vibrio alginolyticus*. *Microbiology* 144:2281–2289
- Nyholm SV, Stabb EV, Ruby EG, McFall-Ngai MJ (2000) Establishment of an animal-bacterial association: recruiting symbiotic vibrios from the environment. *Proc Natl Acad Sci USA* 97:10231–10235
- Parra-Lopez C, Baer MT, Groisman EA (1993) Molecular genetic analysis of a locus required for resistance to antimicrobial peptides in *Salmonella typhimurium*. *EMBO J* 12:4053–4062
- Ruby EG (1996) Lessons from a cooperative, bacterial-animal association: the *Vibrio fischeri-Euprymna scolopes* light organ symbiosis. *Annu Rev Microbiol* 50:591–624
- Ruby EG (1999) Ecology of a benign “infection”: Colonization of the squid luminous organ by *Vibrio fischeri*. In: Rosenberg (ed) *Microbial ecology and infectious disease*. ASM Press, Washington D. C
- Ruby EG, Asato LM (1993) Growth and flagellation of *Vibrio fischeri* during initiation of the sepiolid squid light organ symbiosis. *Arch Microbiol* 159:160–167
- Sambrook J, Fritsch EF, Maniatis T (1989) *Molecular cloning*. Cold Spring Harbor Laboratory Press, Cold Spring Harbor, New York
- Stabb EV, Ruby EG (2003) New RP4-based plasmids for conjugation between *Escherichia coli* and members of the *Vibrionaceae*. *Methods Enzymol* (in press)
- Stabb EV, Reich KA, Ruby EG (2001) *Vibrio fischeri* genes *hvnA* and *hvnB* encode secreted NAD⁺-glycohydrolases. *J Bacteriol* 183:309–317
- Stumpe S, Bakker EP (1997) Requirement of a large K⁺-uptake capacity and of extracytoplasmic protease activity for protamine resistance of *Escherichia coli*. *Arch Microbiol* 167:126–136
- Travis SM, Anderson NN, Forsyth WR, Espiritu C, Conway BD, Greenberg EP, McCray Jr. PB, Lehrer RI, Welsh MJ, Tack BF (2000) Bactericidal activity of mammalian cathelicidin-derived peptides. *Infect Immun* 68:2748–2755
- Visick KL, Ruby EG (1997) New genetic tools for use in the marine bioluminescent bacterium *Vibrio fischeri*. In: Hastings JW, Kricka LJ, Stanley PE (eds) *Bioluminescence and chemiluminescence*. Wiley, New York
- Visick KL, Ruby EG (1998) The periplasmic, group III catalase of *Vibrio fischeri* is required for normal symbiotic competence and is induced both by oxidative stress and by approach to stationary phase. *J Bacteriol* 180:2087–2092
- Visick KL, Skoufos LM (2001) Two-component sensor required for normal symbiotic colonization of *Euprymna scolopes* by *Vibrio fischeri*. *J Bacteriol* 183:835–842
- Visick KL, Foster J, Doyno J, McFall-Ngai MJ, Ruby EG. (2000) *Vibrio fischeri lux* genes play an important role in colonization and development of the host light organ. *J Bacteriol* 182:4578–4586
- Walker JE, Sarasate M, Runswick MJ, Gay NJ (1982) Distantly related sequences in the alpha- and beta-subunits of ATP synthase, myosin, kinases and other ATP-requiring enzymes and a common nucleotide binding fold. *EMBO J* 1:945–951